

WE CAN SERVICE YOUR HOME CARE PACKAGE!

Our customers love us!



★ Trustpilot

May 2022



 **ACORN**  
STAIRLIFTS

**Give your life a lift<sup>®</sup>**  
Enjoy the home you love

# Australia's **NUMBER ONE** selling stairlift

## THE ACORN STAIRLIFTS MISSION:

To be a stairlift company unified in providing a safe and affordable solution to overcome the unique needs and challenges our customers experience on the stairs.



2 | Acorn Stairlifts

“ My wife has felt so much more safe and secure using the stairs. Prior to having an Acorn Stairlift, her use of the stairs was very tentative and unsafe for both her and anyone helping her. ”



Acorn Stairlifts | 3



Acorn Stairlifts is the **ONLY** stairlift company in the world to earn the prestigious Ease of Use Commendation from the Arthritis Foundation.



4 Acorn Stairlifts

## Stay in the Home You Love

Your home is your refuge, where you entertain, welcome family and friends or simply relax. Your home is where you live your life, and the place you call your own.

It is a simple truth that staying in your own home gives you a sense of stability, safety and independence. An important aspect of this is being able to move around freely and easily, without worry, pain, or struggle. So why let getting up and down stairs keep you from fully enjoying your home?

At Acorn Stairlifts, our top priority is and always has been helping our customers to maintain their independence by overcoming the difficulty with their stairs. We pride ourselves on taking the time to speak with each and every person that contacts us, to get to know their unique situation and needs. From more than 25 years in business, we have learned that there are many reasons why a person may benefit from an Acorn Stairlift.

## Arthritis is one of the main reasons people purchase an Acorn Stairlift.



Acorn Stairlifts are innovative on every level, making Acorn the safest alternative for staircase use in every home. As an example of Acorn's commitment to excellence and safety, we are proud that our products have earned the prestigious **Ease of Use Commendation from the Arthritis Foundation**. This commendation is only awarded to companies whose products have passed rigorous testing proving they are easy to use for people with arthritis.

### The Ease-of-Use Programme at a glance.

The Arthritis Foundation created the Ease-of-Use Commendation Programme to encourage manufacturers to design user-friendly products and packaging that could be recommended to the millions of people living with arthritis.

The process begins with the manufacturer submitting a product to the Arthritis Foundation for an extensive scientific evaluation. The sole purpose of this evaluation is to determine, quite simply, how easy to use a given product is for people with arthritis.

## The Acorn 130 Straight Stairlift



Acorn 130 Straight Stairlift

The Acorn 130 Straight Stairlift is our most affordable option and is specifically built for straight staircases only. The Acorn 130 is the perfect choice for anyone with a two-storey home with a straight staircase, or a single-storey home with a basement.



Acorn Stairlifts | 7

Acorn 130 Straight Stairlift



Make sure your stairlift has a seat that swivels, making it very easy to get on or off. It makes a huge difference.





### Mounted to the Stairs

The Acorn 130 is mounted to your steps, making installation quick and easy and eliminating damage to your walls.



### Lock and Diagnostic Display

You'll always have peace of mind with standard technology that includes the diagnostic display, safety belt and key lock.



### Slim Compact Design

Every Acorn Stairlift is made to fold up to allow others to access the staircase.



### Hinged Rail

The hinge is an excellent option to avoid blocking a door or walkway at the bottom of the stairs.

## As Easy as a Touch of a Button

Acorn Stairlifts are simple to use. We've engineered paddle switches at the end of each armrest that control the movement of the stairlift. The ergonomic design of the armrests, coupled with the easy touch paddle switches, make it easy to use by anyone with dexterity challenges. There is a paddle switch on each armrest so you can operate the stairlift with either your left or right hand.



Paddle Switches

## Two User-Friendly Remote Controls

Another way to control the stairlift is with our one-touch remote controls. For extra convenience we provide two wireless remotes with every lift, one for the user and one for anyone who may be assisting those on the stairlift.



Acorn 130, Remote Control

## Safety Sensors

With 12 safety sensors located throughout critical areas of the stairlift, you and your loved ones will never need to worry. Safety sensors on the footrest and carriage stop the lift automatically should there be any obstruction on your staircase.



Acorn 130, Safety sensors on footrest

## Retractable Safety Belt

Safety belts are important to keep you safe and secure during the stairlift operation. They provide peace of mind by ensuring that whoever is using the stairlift will never need to worry. Safety belts are standard on every Acorn Stairlift. They are easy to use and conveniently retract automatically.



Secure, retractable Safety Belt

## Acorn 130 Straight Stairlift

- 1 Footrest Up
- 2 Footrest Down
- 3 Footrest Under
- 4 Upper Arm Interlock
- 5 Lower Arm Interlock
- 6 Seat Interlock
- 7 Upper Safety Cover
- 8 Lower Safety Cover
- 9 OSG Overtravel
- 10 3 Limit Switches



## Advanced Safety Features

Australian Standard AS 1735.7-1998

At Acorn Stairlifts, safety is our top priority. This is why we've made sure every stairlift includes all the safety features needed to ensure you and your loved ones are protected on or around the stairlift.

One of the most important safety features on all Acorn Stairlifts is the "soft-start" and "soft-stop" function. This feature uses advanced programming to ensure a safe and comfortable ride by providing a gradual and smooth start and stop of the stairlift every time it is used.



## Feel Safe in Your Home

Your home should be a safe haven. It's where you raise a family, create memories and share your life with the ones you love. Acorn Stairlifts is committed to helping you stay in your home even as you age or encounter mobility challenges. Acorn Stairlifts is the world leader in stairlifts and has the experience to provide you with the customised solution for your individual needs.

Acorn stairlifts are designed for fast installation, with a range of highly innovative features that conform to the most stringent safety standards.

## The Acorn 180 Curved Stairlift



Acorn 180 Curved Stairlift

The Acorn 180 Stairlift is the most innovative stairlift in the world because it offers a truly customised solution. The Acorn 180 Stairlift is a technological breakthrough that can be installed on virtually any staircase, including those with curves, multiple landings, and more. With a range of available options to choose from, each Acorn 180 Stairlift is designed and installed to your precise requirements. These are just a few of the reasons why we have hundreds of thousands of satisfied customers throughout the world.



Acorn 180, Internal 180° Bend

You need to reach all areas of your home to truly enjoy every room and amenity. Giving you access to second-floor bedrooms and bathrooms, or providing a way to travel down to your basement, is the most important aspect of what we do. With an Acorn Stairlift, you can go up to second floor bedrooms and bathrooms, down to the family room to enjoy gatherings with your loved ones or descend to a basement office or playroom.



Acorn 180 Curved Stairlift



## Maximum Benefit, Minimum Impact

Acorn Stairlifts are installed directly on the steps - not on the wall. This means that there's no mess, no fuss, and no need for any structural alterations to your home.

The Acorn 180 is capable of making very tight turns.



Acorn 180, 90° bend

## Your Stairs Remain Fully Usable by Others

During everyday use or those special occasions when the home is filled with family and loved ones, the Acorn Stairlift's slim design features arms, seat and footrest that fold away with ease, allowing others full access to the stairs.



Acorn 180, Folded at top of stairs

Acorn 180 Curved Stairlift - Powered Hinge



The Powered Hinge is an excellent option to avoid blocking a door or walkway at the bottom of the stairs.



### 180° Wrap

This option creates the perfect parking position. With a 180-degree wrap-around, not only does the stairlift park away from the staircase, it does so in an ideal position to enter and exit safely. This is especially important when transferring to and from a wheelchair or walker.



### 90° Wrap

Much like the 180-degree wrap, the 90-degree wrap is also an excellent option that allows the stairlift to park away from the staircase. Many times this option is used when you want the stairlift to take you to a hallway to access your bedroom.

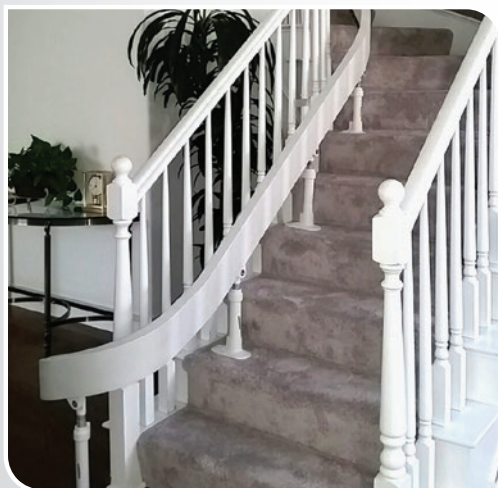

### Elegant Design

Our unique rail system is what allows Acorn to install a Stairlift on virtually any type of staircase, regardless of turns, curves or landings. The Acorn 180 rail is powder-coated white for a long lasting finish. The modular rail design allows us to install your Acorn Stairlift in a way that complements the beauty of your home.



### Standard Park

The standard parking option will bring your stairlift to the top of the stairs, where the footrest is level with the top step. Simply push on the lever on the side of the seat and the seat will swivel 90 degrees into a locked position. This puts both feet on the landing, facing you away from the steps and allowing you to comfortably and safely enter and exit the Acorn Stairlift on each use.

## Acorn 180 Curved Stairlift

- 1 Footrest Up
- 2 Footrest Down
- 3 Footrest Under
- 4 Upper Arm Interlock
- 5 Lower Arm Interlock
- 6 Seat Interlock
- 7 Upper Safety Cover
- 8 Lower Safety Cover
- 9 OSG Overtravel
- 10 3 Limit Switches
- 11 Upper PSE Switch
- 12 Lower PSE Switch
- 13 OSG Opti-Eye
- 14 Final Limit Switch
- 15 Tilt Switch Assembly
- 16 Level Motor Encoder



## Advanced Safety Features

Australian Standard AS 1735.7-1998

All Acorn Stairlifts are easy to use, easy to maintain, and all feature the very best in design, engineering and safety. The Acorn 180 Curved Stairlift has all the same safety features as the Acorn 130 and more. There are additional features built to keep you safe and provide a smooth ride around the curves of your stairs.

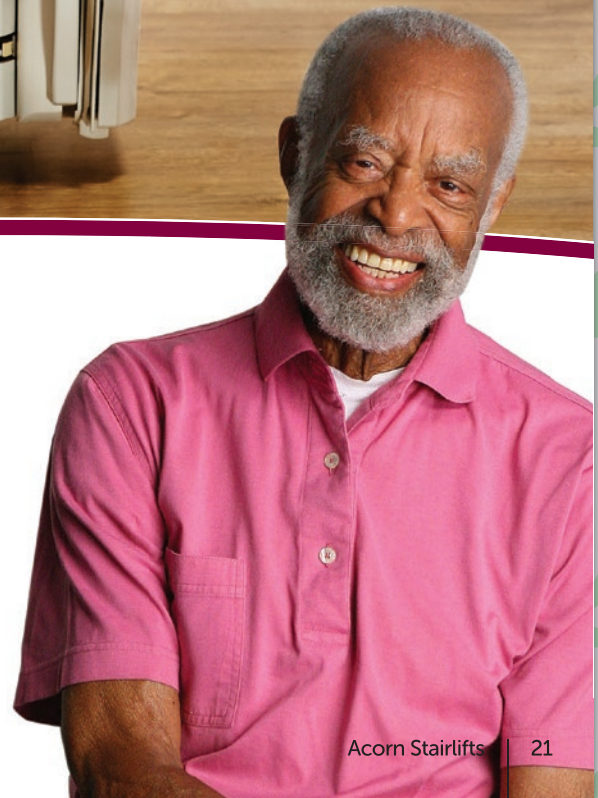

"Incredible technology. It solves my stair climbing problem with severe lower back pain."

Acorn Stairlifts | 21

## The Acorn 130 Outdoor Stairlift



This Acorn Stairlift is the perfect solution for anyone who struggles with their patio or porch steps. With all of the same features as the Acorn 130 Stairlift, the Acorn Outdoor stairlift is weather sealed to International Protection Code IP55 to protect it from the elements. While regaining access within your home is top priority, it's equally important for you to enjoy the freedom of being able to go outside your home to a garage, front porch, or patio.

### Any Outdoor Need

---

The Acorn 130 Outdoor Stairlift can be used for virtually any outdoor application, such as front entry steps, patios, decks, steps to and from a garage, and even to a boat dock or landing.



### Waterproof Cover

---

Enjoy the home you love, both inside and out. The Acorn 130 Outdoor Stairlift is weatherproof and comes with a durable, waterproof cover for extra protection.



ACORN  
STAIRLIFTS

...WITH A SPLASH OF COLOUR!



NOW OFFERING

NEW SEAT COLOURS

An Acorn stairlift delivers easy access to all of your home as often as you like, and – most important of all – it keeps you safe on the stairs.

For the first time, our stairlifts are now available with a choice of five new colour options for a little extra panache or to better blend with your home's décor.

RUBY RED | SAGE GREEN | CHARCOAL GREY | STEEL GREY | STONE



## ACORN STAIRLIFTS - POWERED OPTIONS

Acorn Stairlifts is pleased to advise that we can now offer powered options for both the A180 Curved Stairlift and A130 Straight Stairlift. This includes powered footrests, auto powered swivel and the auto powered hinge.

### The Acorn Powered Footrest

**Our powered footrests assist customers who struggle with bending to lift up the footrest.**

**Features:**

- Available for both Indoor Curved and Indoor Straight stairlifts.
- Easy to use push button situated on top side of the seat that the customer presses to raise the footrest without the need to bend over.
- Allows seat to be folded up when not in use to keep thoroughfares clear and the home tidy.

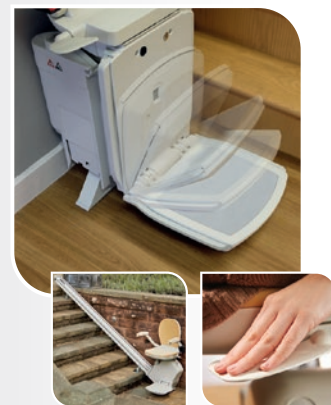

### The Acorn Auto Powered Swivel Seat

**The auto powered swivel seat assists customers at the top of their stairs in situations where they are unable to use a manual swivel lever due to limited coordination or mobility.**

**Features:**

- Available for both Curved and Straight stairlifts.
- The Auto powered swivel has no extra buttons to have to remember.
- The Auto powered swivel requires little strength in the customers arms, simply press the directional toggle or remote on the arm rest and the seat swivels.
- Remote controls are available where full assistance is required.



**Give your life a lift<sup>®</sup>**  
Enjoy the home you love



## You are in Good Hands

We want to make sure that you get the best performance from your Acorn Stairlift the very first time you use it, and for years to come. Our dedicated customer service team is available to help you seven days-a-week and we offer a limited warranty as well as priority call-out service from an Acorn Certified Technician.

We pride ourselves on the excellence and diligence of our people. You can rest assured that each and every person you deal with at Acorn Stairlifts is professionally trained and committed to providing you with the very best and safest stairlift possible.



### Expert Installation

Our attention to detail during installation ensures that your stairlift is built precisely to the requirements of your staircase and takes up the minimum amount of space.



### Hands-On Demonstration

All of the stairlift features are double checked and then demonstrated to you by an Acorn Certified Technician to give you complete peace of mind.



### Modular Rail System

Our unique modular rail system enables Acorn Stairlifts to deliver the solution that is custom designed to your individual mobility requirements.



### Your 100% Satisfaction

Our technician won't leave your home until they are 100% confident that they have achieved the very best installation so you can enjoy years of trouble-free operation.



Each component of the Acorn Stairlift is engineered and assembled with both care and precision.



### Precise Engineering

The highest level of attention to detail and precision engineering goes into every stairlift we produce.



### Rack and Pinion

Our rack and pinion system ensures a smooth and dependable ride while allowing the stairlift to operate quietly. We have eliminated the noisy chains and unreliable cables that other companies use. Rack and pinion technology allows the stairlift to start and stop with precision and smoothness.

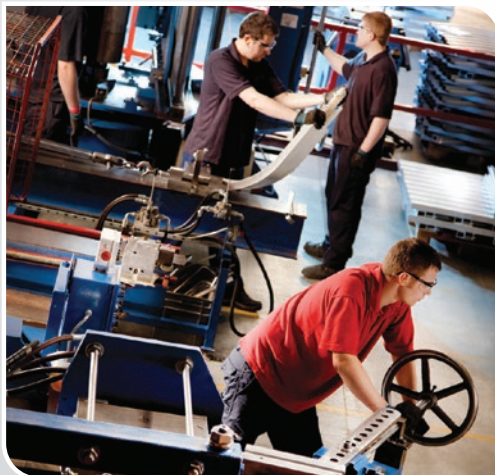

### Innovative Technology

Acorn Stairlifts are fundamentally superior to others because they feature the most innovative and reliable technology available. Every Acorn Stairlift is DC powered, and comes standard with a diagnostic system and numerical display to ensure you always know your lift is operating correctly.



### Highest Quality

Acorn has invested millions of dollars in its manufacturing facilities to ensure every stairlift is of the highest quality and provides long-term dependability. Every component and part we use undergoes numerous quality inspections before a stairlift is assembled.

ACORN STAIRLIFTS



Over 700,000 Satisfied Customers Worldwide and Counting...

Acorn is the world's biggest company dedicated solely to the manufacture, direct sale, installation and maintenance of home stairlifts. As people enjoy longer lives and wish to remain living independently at home, the demand for domestic stairlifts continues to grow.

Acorn manufactures more than 70,000 straight and curved stairlifts per year at its factories in the United Kingdom. As well as supplying its home market, the family-owned company exports to 80 countries and has wholly-owned subsidiaries operating in Australia, New Zealand, Germany, Italy, South Africa, Canada and the USA, where it is the established market leader.

We employ almost 1,500 people worldwide, with frequent opportunities to join the dynamic team which is working hard to make Acorn the world's best stairlift provider.



## The Acorn Stairlifts Family

For more than 25 years, Acorn Stairlifts has been at the forefront of the stairlift industry. We have led the way in innovation and design, always striving to build each and every stairlift solely with our customers in mind.

We receive countless letters and comments from our customers every day, letting us know the difference an Acorn Stairlift has made in their lives. They're now part of the Acorn Family. Now it's your turn to become part of the Acorn Stairlifts family too.

## WHAT OUR CUSTOMERS ARE SAYING:



“I have always found your staff in the different departments to be pleasant, friendly, helpful and respectful – attributes which are becoming somewhat rare these days! I would not hesitate to recommend Acorn to anyone.  
Good company, good product, good service.”

Susan Flynn – Toogoom, Queensland

“From the first phone call to installation – amazing service, amazing products, amazing implementation, outstanding customer experience. Thank you !”

Tamsin Jones - Bentleigh East, Victoria

“My recent experience with the Sydney office of Acorn Stairlifts has been one of absolute satisfaction. I have worked in customer service roles most of my life and would like to congratulate Acorn Stairlifts with this well-deserved feedback. I will not hesitate to highly recommend your company anytime.”

Carolyn Jackson -  
O'Halloran Hill, Adelaide

## Did You Know?

- Every 8 minutes, an Acorn stairlift is installed somewhere in the world.
- Every year, more than 500 of our customers recommend us to a friend or family member.
- Acorn Stairlifts are the only stairlifts in the world that have earned the Ease of Use Commendation from the Arthritis Foundation.

## Acorn Quality and Engineering

### The advanced quality and engineering in every Acorn Stairlift:

1. Unique and revolutionary FastTrack<sup>®</sup> system that can fit even the most complex staircase.
2. Certified by UL to comply with the latest ASME A18.1\*, the US and worldwide standards including Australia AS 1735.7-1998 for all quality elevators and lifting devices.
3. The only stairlift in the industry fitted with innovative Smart-Level technology, to ensure the highest level of safety by keeping the stairlift perfectly level while in use.
4. The only stairlift in the world to receive the Ease of Use Commendation from the Arthritis Foundation.
5. Available 3D-Scan and measuring capability to ensure proper fit for all custom staircases.
6. 'Smart carriage' printed circuit board technology that actively monitors use and communicates lift status at all times, which provides easy troubleshooting for the Acorn Certified Technician.
7. Each Acorn drive unit is tested/inspected to a 180-point standard by our quality assurance team.
8. Acorn Certified Installation Technicians work through a rigorous 37-point checklist as part of the installation process and must certify each install to Australia AS 1735.7-1998 standard before completion.
9. Acorn Stairlifts take up little room on the staircase, leaving plenty of space for others in the home to use the staircase normally.
10. Acorn Stairlifts Installation and Service Technicians are certified directly by the manufacturer to install and inspect to all applicable worldwide standards (Australia AS 1735.7-1998, ASME A18.1, CSA, BSI, Intertek and EN standards).





## Acorn's Warranty Terms & Conditions

1. Our goods come with guarantees that cannot be excluded under the Australian Consumer Law (ACL). You are entitled to a replacement or a refund for a major failure and for compensation for any other reasonable foreseeable loss or damage. This Warranty provides some benefits which are additional to your ACL rights, however some of the benefits may overlap with your ACL rights.
2. In these terms, the words "we" shall refer to Acorn Stairlifts Pty Ltd, "you" refers to the party who has purchased the stairlift equipment (under the terms and conditions of sale of the stairlift equipment "Order Form"), and Warranty shall mean the 12 month Warranty.
3. The terms of the Warranty shall commence immediately after the installation of the stairlift equipment.

### Benefits of the Warranty

4. All costs covered including for wear and tear (except batteries). During the term of the Warranty we will cover all costs of call outs, labour and parts (excluding batteries which are chargeable at the then current rates). We also warrant the original purchaser a lifetime warranty on the major components of the lift (this includes the motor and gearbox) are free of defects in materials and workmanship under normal use and maintenance for as long they own the stairlift. To maintain this lifetime warranty and to avoid denied warranty claims you must have an annual service performed on your stairlift (this is already included in the price in the first year). This lifetime warranty is not transferable.
5. **Annual service**  
During the term of the Warranty we will inspect, lubricate and adjust the stairlift equipment with due care and skill, at no charge once during the first 12 months of the Warranty within normal working hours (Monday - Friday 8am - 5pm)
6. **Priority attention**  
Warranty customers will always be treated as a priority during the term of the Warranty and we will always try to attend a breakdown as soon as practical.
7. **Repair or replace**  
Subject to the exceptions in clause 8 below for repairs that are not covered, during the term of the Warranty, we agree to repair your stairlift equipment with due care and skill unless we cannot reasonably obtain the spare parts necessary for repair, or we can replace the stairlift equipment for less than the cost of repair, in which case, we will replace your stairlift equipment free of charge with another stairlift of the same or similar quality.
8. **Conditions**  
We are not legally responsible for repairs to the equipment arising from: abuse, misuse, neglect by the owner or any third party, theft, fire, flood, or costs arising from a failure to follow manufacturer's instructions, or for costs we may incur when no fault is found.
9. The Warranty covers the stairlift equipment while installed at the property. Unless we agree otherwise, the warranty will not continue if the stairlift is removed from the property and re-installed elsewhere. The costs (including mileage) associated with the relocation of any installed stairlift equipment by Acorn, are not included within the Warranty and you will be responsible for any such costs to Acorn.

## A Helpful Guide to Buying your Stairlift

We have developed a detailed guide listing the important things to consider when buying a stairlift. It outlines the features and benefits of a safe and easy-to-use stairlift that will suit your individual needs. Be sure your stairlift includes the following:

1. It is vital that your stairlift has safety sensors that automatically cut off power to the lift when the sensors detect an obstruction.
2. Choose a stairlift with a swivel seat so you have safe and easy entry and exit on and off the chair.
3. Look for a stairlift that includes “soft-start” and “soft-stop” as standard features. This ensures a smooth, safe and comfortable ride.
4. Make sure the lift runs on DC power so that it will continue to operate should you lose power in your home.
5. Look for a remote control feature for added convenience, especially when more than one person needs to use the lift.
6. The switch or paddle controls should not require much force, making them easy to operate for those with limited dexterity.
7. A secure, retractable safety belt should be included for extra security, stability and peace of mind.
8. The best stairlifts have a digital display, which allows you to diagnose any simple error on the rare occasion that something may occur.
9. The stairlift should be fully customisable to suit the individual needs of you and your home.
10. The components of the stairlift should be of the highest quality and undergo appropriate inspections to ensure safe and reliable operation.
11. Your stairlift should come from a company that only produces stairlifts and is focused on being the best in the world at it.
12. **MOST IMPORTANT:** Your stairlift should come from a team of dedicated professionals who put your needs above anything else.

## Technical Specifications

### Acorn 180 Curved Stairlift

	inch	mm
A Floor to top of footrest	2	50
B Top of footrest to top of seat	19	485
C Top of seat to top of arms	9¾	245
D Top of arms to top of seat back	7¾	195
E Width between armrests	19	480
F Overall width including seatbelt	24¼	620
G Overall height	38¼	975
H Length of arms from seat back	18	460
I Length of seat base from seat back	17	435
J Length of footrest	14¼	360
K Width of footrest	14¼	375
L Front of footrest to stringer	25¼	640
M Back of seat to stringer	1½	35
N Folded width	13¼	335
O Minimum width required to swivel at top	27½	700
P Distance from front of rail to stringer	7	180
Q Height of leg	5 <sub>(min)</sub> 25½ <sub>(max)</sub>	125 <sub>(min)</sub> 650 <sub>(max)</sub>
R Front of drop nose to first stair	17¾	450

### Specifications

Motor Power	0.375KW
Motor Output Speed	No greater than 0.15 m/s
Method of Drive	Rack and Pinion
Battery Power Supply	29.6V DC
Maximum Capacity	120kg
Track	Extruded Aluminum
Main Power Supply	240V AC, 1.5 amp charger supplied

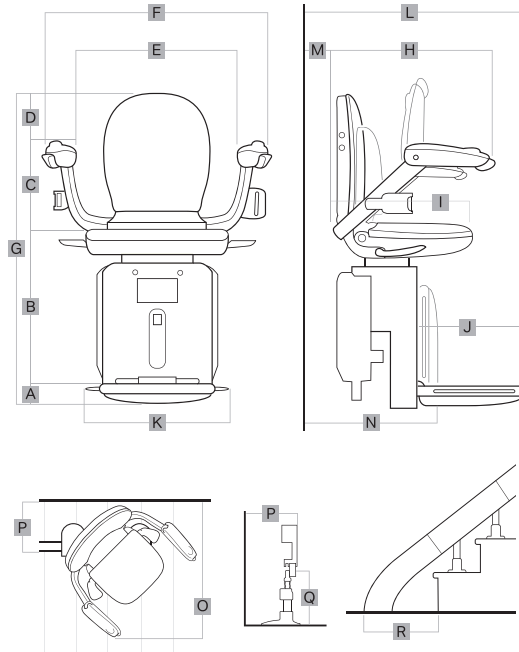

### Acorn 130 Straight Stairlift

	inch	mm
A Floor to top of footrest	3¾	95
B Top of footrest to top of seat	17½	445
C Top of seat to top of arms	9¾	250
D Top of arms to top of seat back	7½	190
E Width between armrests (Wide arm version)	17½(19½)	445(495)
F Overall width	24	605
G Overall height	38½	980
H Length of arms from seat back	18½	470
I Length of seat base from seat back	17	435
J Length of footrest	12¾	325
K Width of footrest	12¼	310
L Front of footrest to stringer	22½	570
M Back of seat to stringer	½	13
N Folded width	12¼	310
O Minimum width required to swivel at top	26¼	670
P Distance from front of rail to stringer (Wide arm version)	8½(9½)	215(240)

### Specifications

Motor Power	0.25KW
Motor Output Speed	No greater than 0.15 m/s
Method of Drive	Rack and Pinion
Battery Power Supply	24V DC
Maximum Capacity	127kg
Track	Extruded Aluminum
Main Power Supply	240V AC, 1.5 amp charger supplied

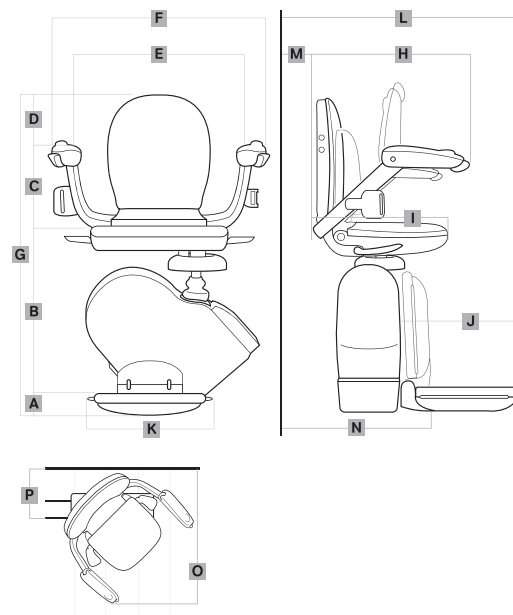

Acorn reserves the right to change specifications without notice. All measurements are approximate. Images are shown for illustrative purposes only. Product may vary slightly.

# Comfort is only a call away.



All Acorn Stairlifts carry the  
Arthritis Foundation's Ease-of-Use  
Commendation



Copyright 2022 Acorn Stairlift Pty Ltd. All rights reserved. Acorn reserves the right to change specification without prior notice. All measurements are approximate. Images are shown for illustrative purposes only. Product may vary slightly. All information correct at time of going to print. E&OE.